

- Low Leakage
- SCR Output
- Panel Mount
- Zero Voltage Switching
- Wide Control Range

The Series CS has an SCR AC switch output featuring low off-state leakage (1mA, snubberless), zero-voltage switching and a broadened operating range (24-280Vac). This wide range permits optimum performance at both 120Vac and 240Vac line voltages.

Manufactured in Crydom's ISO 9001 Certified facility for optimum product performance and reliability.

MODEL NUMBERS

CSW2410 CSW2425 CSW2450 CSW2475 CSW2490

OUTPUT SPECIFICATIONS ①

	CSW2410	CSW2425	CSW2450	CSW2475	CSW2490
Operating Voltage (47-63 Hz) [Vrms]	24-280	24-280	24-280	24-280	24-280
Load Current Range ③ [Arms]	0.15-10	0.15-25	0.15-50	0.25-75	0.25-90
Transient Overvoltage [Vpk]	600	600	600	600	600
Max. Surge Current, (16.6ms) [Apk]	120	250	625	1000	1200
Max. On-State Voltage Drop @ Rated Current [Vpk]	1.6	1.6	1.6	1.6	1.6
Thermal Resistance Junction to Case (R _{θJC}) [°C/W]	1.48	1.02	0.63	0.31	0.28
Maximum I ² t for Fusing, (8.3 msec.) [A ² sec]	60	260	1620	4150	6000
Max. Off-State Leakage Current @ Rated Voltage [mA]	1.0	1.0	1.0	1.0	1.0
Min. Off-State dv/dt @ Max. Rated Voltage [V/μsec] ②	500	500	500	500	500
Max. Turn-On Time	1/2 Cycle	1/2 Cycle	1/2 Cycle	1/2 Cycle	1/2 Cycle
Max. Turn-Off Time	1/2 Cycle	1/2 Cycle	1/2 Cycle	1/2 Cycle	1/2 Cycle
Power Factor (Min.) with Max. Load	0.5	0.5	0.5	0.5	0.5

INPUT SPECIFICATIONS ①

DC CONTROL

Control Voltage Range	3-32 Vdc
Max. Turn-On Voltage	3 Vdc
Min. Turn-Off Voltage	1.0 Vdc
Nominal Input Impedence	See note 4
Typical Input Current	10mA @ 12 Vdc

GENERAL NOTES

© 2006 CRYDOM CORP, Specifications subject to change without notice.

① Off-State dv/dt test method per EIA/NARM standard RS-443, paragraph 13.11.1

② All parameters at 25°C unless otherwise specified.

③ Heat sinking required, for derating curves see page 2.

④ Input Circuit Incorporates Active Current Limiter.

GENERAL SPECIFICATIONS

Dielectric Strength 50/60Hz , Input/Output/Base	4000 Vrms
Insulation Resistance (Min.) @ 500 Vdc	10 ⁹ Ohm
Max. Capacitance Input/Output	10 pF
Ambient Operating Temperature Range	-40 to 80°C
Ambient Storage Temperature Range	-40 to 125°C

MECHANICAL SPECIFICATIONS

Weight: (typical)	3.0 oz. (86.5g)
Encapsulation:	Thermally Conductive Epoxy
Terminals:	Screws and Saddle Clamps Furnished, Unmounted

AVAILABLE OPTIONS

- F** Faston Terminals (Up to 50A Models)
Example: **CSW2425F**
- G** Input Status LED.
Example: **CSW2425G**
- P** Internal Overvoltage Protection.
Relay Will Self Trigger Between
450-600 Vpk. Not Suitable For Capacitive Loads.
Example: **CSW2425P**
- 10** Phase Controllable
Example: **CSW2425-10**
- H** Heat Transfer Pad (Attached)
Example: **CSW2425H**

Screw Torque Requirements:

6-32 Screws - 10 in./lbs.,
8-32 and 10-32 Screws - 20in./lbs.
(Screws dry without grease.)

Fastons:

Single pair (up to 25A)
Double pair* (up to 50A).
* Caution: User must connect to both pairs

Crydom Heat Sinks offer excellent thermal management and are perfectly matched to the load current ratings of Crydom panel mount relays. Request Crydom's Heat Sink specification sheet for all the details.

EMC Compatibility

Input:	EN61000-4-2, Level 3	ESD
	EN61000-4-4, Level 3	Burst
Output:	EN61000-4-2, Level 3	ESD
	Level 4	ESD (with P option)
	EN61000-4-4, Level 3	Burst
	Level 4	Burst (with P option)
	EN61000-4-5, Level 4	Surge

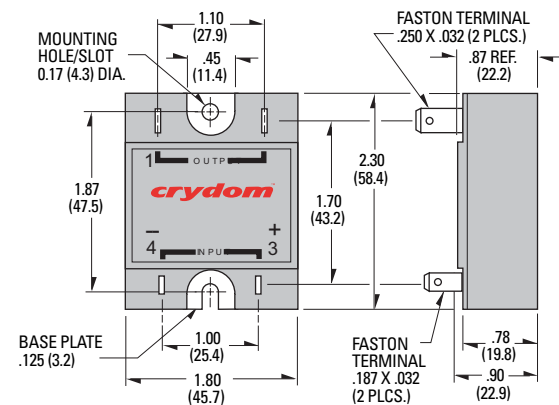
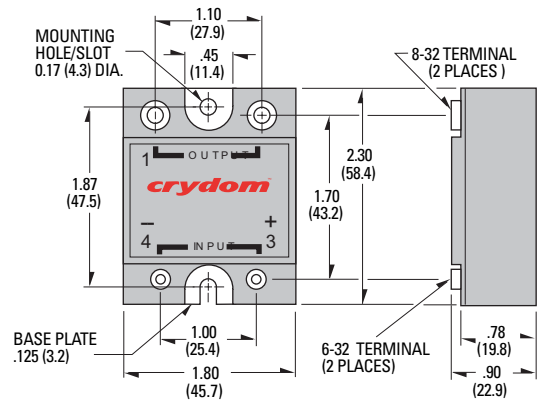

All dimensions are in inches (millimeters)

APPROVALS

UL E116949
CSA LR 81689-10
VDE 10143 UG

© 2006 CRYDOM CORP, Specifications subject to change without notice.

